

DISCOVERER INSPIRATION

ULTRA-DEEPWATER DUAL-ACTIVITY DRILLSHIP



For additional information please contact:

Transocean
Marketing Department
4 Greenway Plaza
Houston, TX 77046, USA
Phone: + 1-713-232-7500
Fax: + 1-713-232-7880
marketing@deepwater.com
www.deepwater.com

General Description

Design / Generation	Transocean Offshore Enhanced Enterprise Class
Constructing Shipyard	DSME
Year Entered Service / Significant Upgrades	2008
Classification	DNV, 1A1
Flag	Marshall Islands
Dimensions	835 ft. long x 125 ft. wide x 62 ft. deep
Drafts	42 ft. operating
Accommodation	200 persons
Displacement	98,421 st operating
Variable Deck	22,046 st operating / 22,046 st transit
Transit Speed	up to 12 knots
Maximum Water Depth	12,000 ft. designed / 10,000 ft. outfitted
Maximum Drilling Depth	40,000 ft

Drilling Equipment

Derrick	NOV Dual Activity derrick, 226 ft. high, with 80 ft. x 80 ft. base.
Hookload Capacity	(Main) 2,500,000 lbs. gross nominal capacity (Aux) 2,500,000 lbs. gross nominal capacity
Drawworks	(Main): NOV Active Heave Drawworks with 6 x General Electric GEB-22A2 motors rated at 6,900 total hp. 1,050 st rated hook load with 2 inch drill line (Aux): NOV Active Heave Drawworks with 6 x General Electric GEB-22A2 motors rated at 6,900 total hp. 1,050 st rated hook load with 2 inch drill line
Compensator	(Main) active heave drawworks above (Aux) active heave drawworks above
Rotary Table	(Main) 1 x NOV 75-1/2 inch hydraulic (Aux) 1 x NOV 60-1/2 inch hydraulic
Top Drive	(Main) Maritime Hydraulics MDDM 1250-AC rated at 1,250 st motor, and rated to 101,200 ft.-lbs. continuous drilling torque in low gear (Aux) Same as above
Tubular Handling	2 x NOV PRS-5 pipe racking system, and 2 x NOV AR 4500 Iron Roughnecks
Mud Pumps	5 x NOV HEX 240 pumps, each driven by 2 x Baylor traction motors
HP Mud System	Rated for 7,500 psi
Solids Control	10 x Brandt LCM-3D/CM-2 shale shakers

Power & Machinery

Main Power	6 x MAN B&W V32/40 14 cylinder diesel engines rated at 7,000 kW, each driving 1 x LDW-Siemens generator
Emergency Power	1 x MAN B&W 7L27/38 diesel engine rated 2,310 kW, driving 1 x Hyundai 2,100 kW generator
Power Distribution	Siemens 11 kV switchboards with Siemens Blue Variable Speed generator protection

Storage Capacities

Fuel Oil	36,000 bbl
Liquid Mud	20,000 bbl active
Base Oil	9,215 bbl
Brine	20,288 bbl
Drill Water	13,700 bbl
Potable Water	5,000 bbl
Bulk Material	(mud + cement) 32,000 cu.ft.
Sack Storage	16,000 sacks

BOP & Subsea Equipment

BOP Rams	3 x Hydril 18-3/4 inch 15,000 psi Compact Double Ram Preventers (1 x 6-ram preventer)
BOP Annulars	1 x Hydril Annuflex 18-3/4 inch 10,000 psi annular preventer
2nd BOP Stack	1 x BOP stack with the same components as the primary stack listed above, including 1 x annular
BOP Handling	BOP skid system comprised of 3 x 350 st rated BOP carts; 2 sets of spider beams rated to 350 st per set
Marine Riser	Vetco HMF 21 inch OD x 75 ft. long per joint. Class G couplings and 2 x 4-1/2 inch 15,000 psi choke and kill lines
Tensioners	6 x Hydralift riser tensioners, rated at 400 st each with a 50 ft. stroke
Diverter	Vetco CSO with a 72 inch opening 500 psi diverter with 2 x 16 inch flow lines
Tree Handling	3 x 100 st Xmas tree trolley
Moonpool	72 ft. length x 30 ft. width.

Station Keeping / Propulsion System

Thrusters	6 x Rolls Royce Aquamaster thrusters rated at 7,000 hp fully azimuthing
DP System	Kongsberg Maritime Triple Redundant SDP 32 system

Cranes

Cranes	4 x MT Hydralift electro-hydraulic knuckle-boom cranes, rated to a 150 ft lift radius
---------------	---

Other Information

Helideck	Rated for Chinook 234 helicopters
-----------------	-----------------------------------

Revision Date: 20 December 2016



These specifications are intended for general reference purposes only, as actual equipment and specifications may vary based upon subsequent changes, the contract situation and customer needs. All equipment shall be operated and maintained at all times, in compliance with Transocean standard operating manuals, policies and procedures, and within its stated operational limits or continuous rated capacity, in order to assure maximum operational efficiency.

Patent Notice: This rig, its systems, components, and/or equipment in use on this rig, may be protected by one or more US and/or foreign patents.

DISCOVERER INSPIRATION

ULTRA-DEEPWATER DUAL-ACTIVITY DRILLSHIP

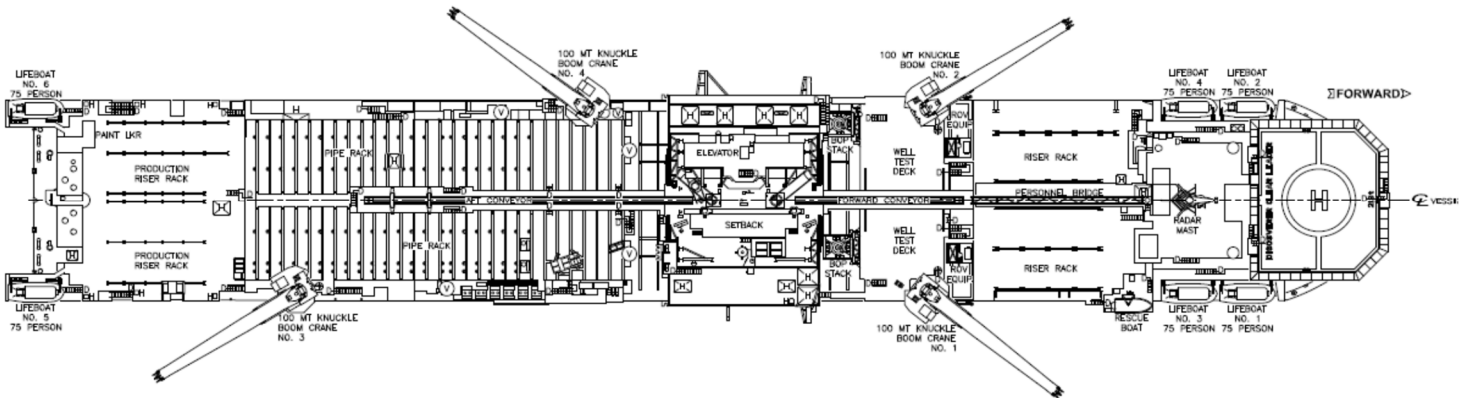
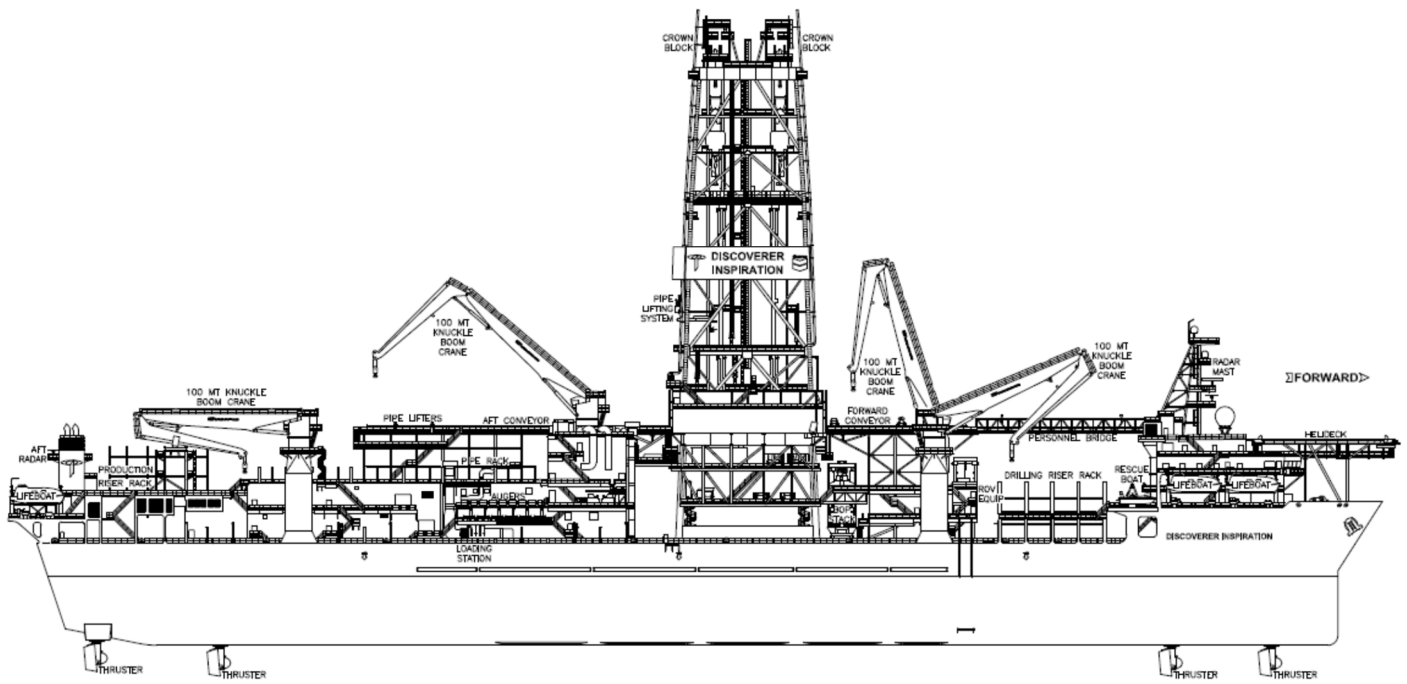

BOUNDLESS

**SERVICE FOCUSED
DATA DRIVEN
PERFORMANCE ORIENTED**

Revision Date: 20 December 2016



These specifications are intended for general reference purposes only, as actual equipment and specifications may vary based upon subsequent changes, the contract situation and customer needs. All equipment shall be operated and maintained at all times, in compliance with Transocean standard operating manuals, policies and procedures, and within its stated operational limits or continuous rated capacity, in order to assure maximum operational efficiency.

Patent Notice: This rig, its systems, components, and/or equipment in use on this rig, may be protected by one or more US and/or foreign patents.